

**NOTICE OF CONFIDENTIALITY**  
 THE INFORMATION CONTAINED IN THIS DRAWING IS THE SOLE PROPERTY OF BLUE WATER DESALINATION LLC. ANY REPRODUCTION, CIRCULATION, AND DISTRIBUTION IN PART OR AS A WHOLE WITHOUT THE WRITTEN CONSENT OF BLUE WATER DESALINATION LLC IS STRICTLY PROHIBITED.

**TOLERANCES**  
 UNLESS OTHERWISE SPECIFIED:  
 DIMENSIONS ARE IN INCHES AND MILLIMETER

|             |                    |
|-------------|--------------------|
| FRACTIONAL: | ± 1/16" ± 1.5mm    |
| ANGULAR:    | ± 1 DEG            |
| .X          | ± 0.1" ± 2.5mm     |
| .XX         | ± 0.01" ± 0.50mm   |
| .XXX        | ± 0.005" ± 0.127mm |

**Blue Water DESALINATION**  
 2695 Temple Ave  
 Signal Hill, CA, 90755  
 TEL: 1 (562) 426-2412  
 FAX: 1 (562) 426-2449  
 www.BlueWaterDesalination.com

TITLE: **PRELIMINARY - ENERGY RECOVERY UNIT (ADVANCED)**

|           |      |
|-----------|------|
| APPROVALS | DATE |
| DRAWN     |      |
| CHECK     |      |
| MFG       |      |
| QUAL      |      |
| CHIEF     |      |

|          |                |           |
|----------|----------------|-----------|
| SIZE     | DRAWING NUMBER | REV       |
| <b>C</b> |                | <b>NR</b> |

SCALE: WEIGHT: SHEET 1 OF 5

DO NOT SCALE DRAWING

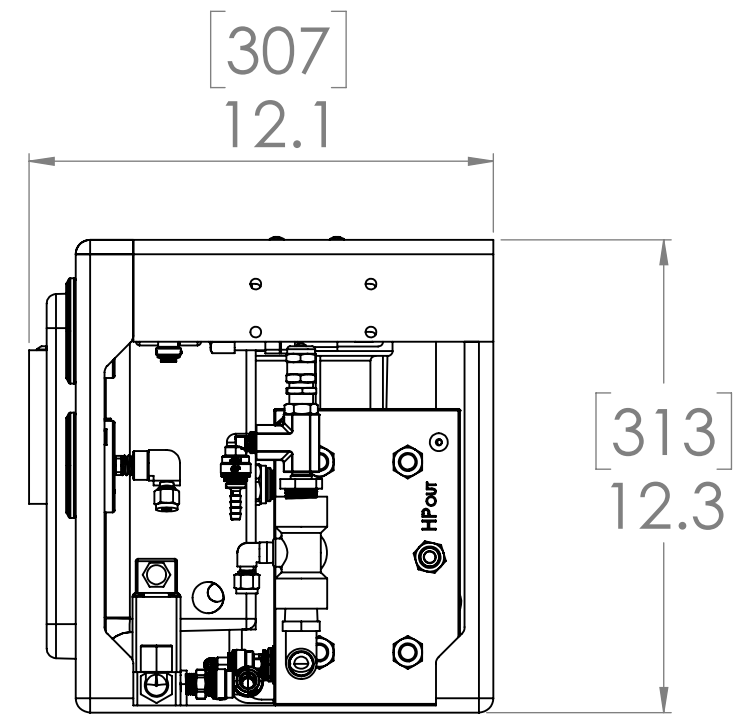
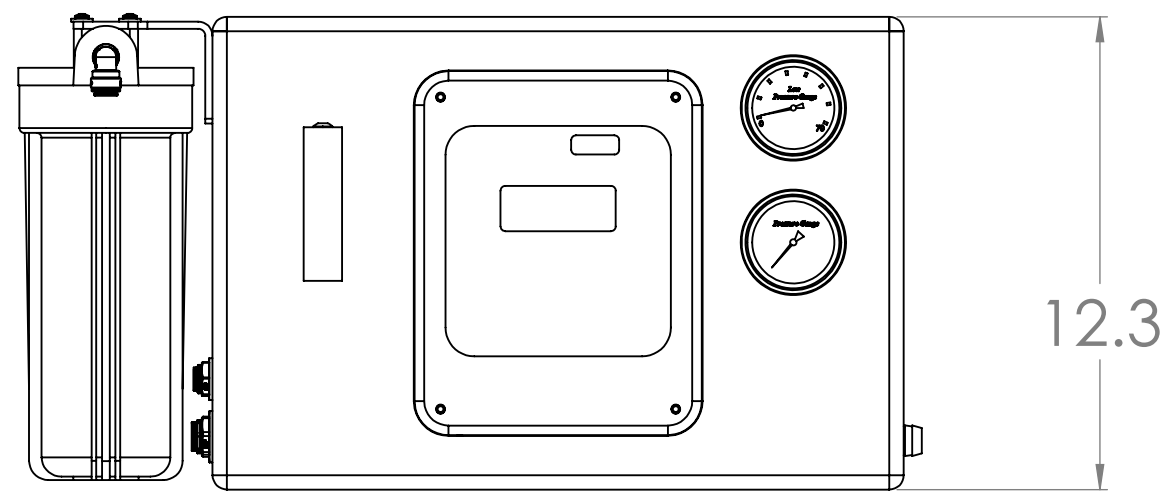
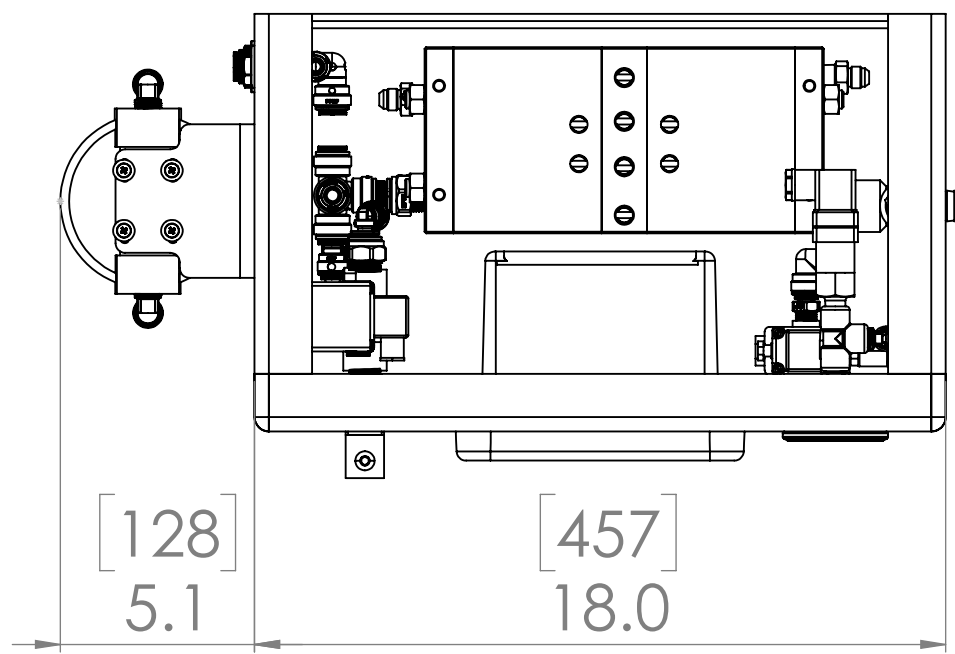

**NOTICE OF CONFIDENTIALITY**  
 THE INFORMATION CONTAINED IN THIS DRAWING IS THE SOLE PROPERTY OF BLUE WATER DESALINATION LLC. ANY REPRODUCTION, CIRCULATION, AND DISTRIBUTION IN PART OR AS A WHOLE WITHOUT THE WRITTEN CONSENT OF BLUE WATER DESALINATION LLC IS STRICTLY PROHIBITED.

**TOLERANCES**  
 UNLESS OTHERWISE SPECIFIED:  
 DIMENSIONS ARE IN INCHES AND MILLIMETER

|             |          |           |
|-------------|----------|-----------|
| FRACTIONAL: | ± 1/16"  | ± 1.5mm   |
| ANGULAR:    | ± 1 DEG  |           |
| .X          | ± 0.1"   | ± 2.5mm   |
| .XX         | ± 0.01"  | ± 0.50mm  |
| .XXX        | ± 0.005" | ± 0.127mm |

**Blue Water DESALINATION**  
 2695 Temple Ave  
 Signal Hill, CA, 90755  
 TEL: 1 (562) 426-2412  
 FAX: 1 (562) 426-2449  
 www.BlueWaterDesalination.com

TITLE: **PRELIMINARY - ENERGY RECOVERY UNIT (ADVANCED)**

|           |      |
|-----------|------|
| APPROVALS | DATE |
| DRAWN     |      |
| CHECK     |      |
| MFG       |      |
| QUAL      |      |
| CHIEF     |      |

|          |                |           |
|----------|----------------|-----------|
| SIZE     | DRAWING NUMBER | REV       |
| <b>C</b> |                | <b>NR</b> |

SCALE: WEIGHT: SHEET 2 OF 5

DO NOT SCALE DRAWING